

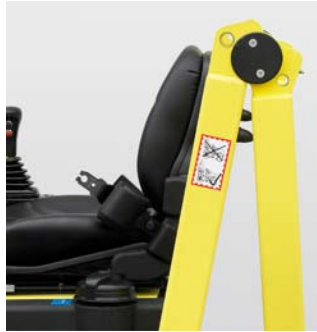

## Technical data and optionals

	Measuring unit	AV 12-2	AV 16-2	AV 16-2 K	AV 20-2
<b>Weight</b>					
Operating weight CECE	kg	1500	1600	1500	1650
Static linear load	kg/cm	9.1	8.8	8.8	8.3
Wheel load	kg	–	–	200	–
French classification		PV2	PV2	PV2	PV2
<b>Drums (Wheels)</b>					
Width	mm	820	900	900	1000
Diameter	mm	575	575	575	575
Thickness	mm	13	13	12	13
Offset	mm	40	40	40	40
Number of wheels		–	–	4	–
Tire size		–	–	205/60R15	–
Tire-axle width	mm	–	–	890	–
Rolling width max.	mm	860	940	900	1040
<b>Drive</b>					
Engine and type		Yanmar 3TNV76 EuroMot2 / EPA4			
1. working speed: 2100 at rpm					
Power output DIN 6270 B	kW / hp	13.2 / 18.0	13.2 / 18.0	13.2 / 18.0	13.2 / 18.0
Travel speed	km/h	0 – 7	0 – 7	0 – 7	0 – 7
Gradeability with / without vibr.	%	30 / 40	30 / 40	30 / 40	25 / 35
2. working speed: 2400 at rpm					
Power output DIN 6270 B	kW / hp	15.2 / 20.7	15.2 / 20.7	15.2 / 20.7	15.2 / 20.7
Travel speed	km/h	0 – 8	0 – 8	0 – 8	0 – 8
Gradeability with / without vibr.	%	30 / 40	30 / 40	30 / 40	30 / 40
<b>Steering</b>					
Tuning radius, outside/inside	mm	2990 / 2170	3030 / 2130	3030 / 2130	3080 / 2080
Steering / Oscillating angle	±°	31 / 5	31 / 5	31 / 5	31 / 5
<b>Vibration</b>					
Amplitude					
1. working speed: 2100 at rpm	mm	0.5	0.5	0.5	0.45
Frequency					
1. working speed: 2100 at rpm	Hz	61	61	61	61
Centrifugal force per drum	kN	13	13	13	13
same per cm drum width	N/cm	158	144	144	130
2. working speed: 2400 at rpm					
Frequency	Hz	67	67	67	67
Centrifugal force per drum	kN	16	16	16	16
same per cm drum width	N/cm	195	178	178	160
<b>Capacities</b>					
Water tank	l	95	95	95	95
Anti-adhesive tank	l	–	–	9	–
Hydraulic tank	l	25	25	25	25
Diesel fuel tank	l	26	26	26	26

Technical data subject to changes



Folding ROPS for easy transportation



2 scrapers per drum

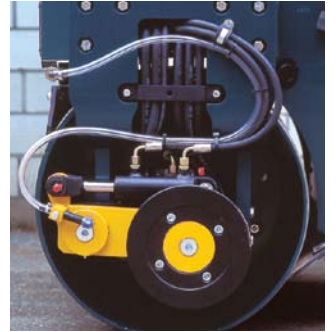

Edge-cutter

## Standard

- Full flush left and right
- Both drums with drive
- Pressurised sprinkler system
- 2 scrapers per drum
- central lifting point
- Diesel fuel gauge
- Hour meter
- Drums 40 mm offset
- Drive lever with vibration- and water switch
- Double vibration
- Lockable water tank

## Optionals

- CE-Kit incl. folding ROPS
- Road lighting
- Rotating beacon
- Reversing alarm
- Battery disconnection switch
- Break release valve
- Edge cutter
- Biodegradable hydraulic oil
- Customer color
- Arm rests

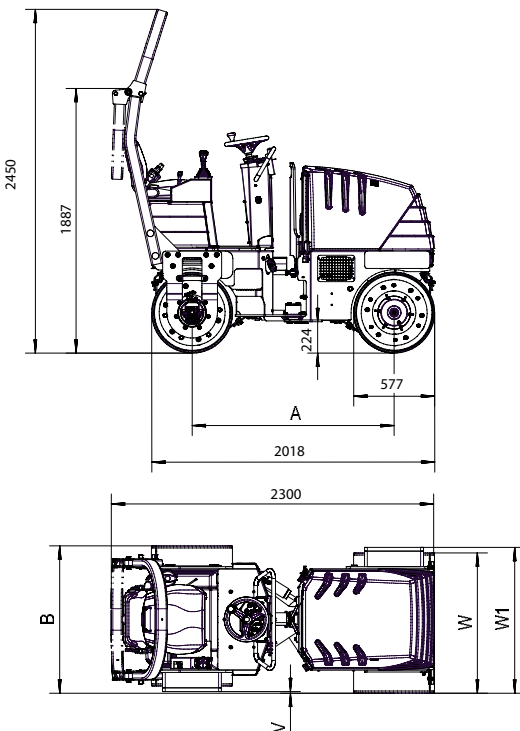

Dimensions	L	B	H	W	W1	V
Measures in mm						
AV 12-2	2300	860	2450	820	860	40
<b>AV 16-2</b>	<b>2300</b>	<b>940</b>	<b>2450</b>	<b>900</b>	<b>940</b>	<b>40</b>
AV 16-2 K	2300	940	2450	900	940	0
AV 20-2	2300	1040	2450	1000	1040	40

Technical data subject to changes.